

Autonics Motor Driver (5-phase Stepper Motor Driver)

MD5-HF28

INSTRUCTION MANUAL

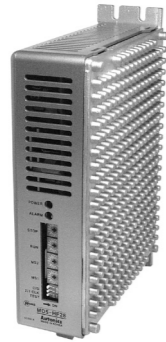

Thank you for choosing our Autonics product. Please read the following safety considerations before use.

■ Safety Considerations

※Please observe all safety considerations for safe and proper product operation to avoid hazards.
 ※⚠ symbol represents caution due to special circumstances in which hazards may occur.

⚠ Warning Failure to follow these instructions may result in serious injury or death.
⚠ Caution Failure to follow these instructions may result in personal injury or product damage.

⚠ Warning

- Fail-safe device must be installed when using the unit with machinery that may cause serious injury or substantial economic loss.** (e.g. nuclear power control, medical equipment, ships, vehicles, railways, aircraft, combustion apparatus, safety equipment, crime/disaster prevention devices, etc.)
Failure to follow this instruction may result in fire, personal injury, or economic loss.
- Do not connect, repair, or inspect the unit while connected to a power source.**
Failure to follow this instruction may result in electric shock or fire.
- Install the unit after considering counter plan against power failure.**
Failure to follow this instruction may result in personal injury, or economic loss.
- Check 'Connections' before wiring.**
Failure to follow this instruction may result in fire.
- For installing the unit, ground it exclusively and use AWG 18(0.75mm²) ground cable.**
Failure to follow this instruction may result in electric shock.
- Do not disassemble or modify the unit.**
Failure to follow this instruction may result in electric shock or fire.
- Insulate the connector not to be exposed.**
Failure to follow this instruction may result in electric shock.
- Install the driver in the housing or ground it.**
Failure to follow this instruction may result in electronic shock, personal injury, or fire.
- Do not touch the unit during or after operation for a while.**
Failure to follow this instruction may result in electric shock or burn due to high temperature of the surface.
- Emergency stop directly when error occurs.**
Failure to follow this instruction may result in fire, or personal injury.

⚠ Caution

- When connecting the power input, use AWG 18(0.75mm²) cable or over.**
- Install over-current prevention device (e.g. the current breaker, etc) to connect the driver with power.**
Failure to follow this instruction may result in fire.
- Check the control input signal before supplying power to the driver.**
Failure to follow this instruction may result in personal injury or product damage by unexpected signal.
- Install a safety device to maintain the vertical position after turn off the power of this driver.**
Failure to follow this instruction may result in personal injury or product damage by releasing holding torque of the motor.
- Use the unit within the rated specifications.**
Failure to follow this instruction may result in fire or product damage.
- Use dry cloth to clean the unit, and do not use water or organic solvent.**
Failure to follow this instruction may result in electric shock or fire.
- Do not use the unit in the place where flammable/explosive/corrosive gas, humidity, direct sunlight, radiant heat, vibration, impact, or salinity may be present.**
Failure to follow this instruction may result in fire or explosion.
- The driver may overheat depending on the environment.**
Install the unit in the well ventilated place and forced cooling with a cooling fan.
Failure to follow this instruction may result in product damage and degradation.
- Keep metal chip, dust, and wire residue from flowing into the unit.**
Failure to follow this instruction may result in fire or product damage.
- Use the designated motor only.**
Failure to follow this instruction may result in fire or product damage.

※The above specifications are subject to change and some models may be discontinued without notice.
 ※Be sure to follow cautions written in the instruction manual and the technical descriptions (catalog, homepage).

■ Specifications

Model	MD5-HF28	
Power supply	100-220VAC ~ 50/60Hz	
Allowable voltage fluctuation range	90 to 110% of the rated voltage	
Max. current consumption ^{*1}	5A	
RUN current ^{*2}	1.0-2.8A/Phase	
STOP current	27 to 90% of RUN current (set by STOP current switch)	
Drive method	Bipolar constant current pentagon drive	
Basic step angle	0.72°/step	
Resolution	1, 2, 4, 5, 8, 10, 16, 20, 25, 40, 50, 80, 100, 125, 200, 250-division (0.72° to 0.00288°/step)	
Input pulse characteristic	Pulse width	Min. 1μs (CW, CCW), Min. 1ms (HOLD OFF)
	Duty Rate	50% (CW, CCW)
	Rising/Falling time	Below 130ns (CW, CCW)
	Pulse input voltage	[H]: 4-8VDC=, [L]: 0-0.5VDC=
	Pulse input current	7.5-14mA (CW, CCW), 10-16mA (HOLD OFF, DIVISION SELECTION, ZERO OUT)
Max. input pulse frequency ^{*3}	Max. 500kHz (CW, CCW)	
Input resistance	270Ω (CW, CCW), 390Ω (HOLD OFF, DIVISION SELECTION), 10Ω (ZERO OUT)	
Insulation resistance	Over. 100MΩ (at 500VDC megger, between all terminals and case)	
Dielectric strength	1,000VAC 50/60Hz for 1min (between all terminals and case)	
Noise resistance	±2000V the square wave noise (pulse width: 1μs) by the noise simulator	
Vibration	Mechanical	1.5mm amplitude at frequency of 5 to 60Hz (for 1 min) in each X, Y, Z direction for 2 hours
	Malfunction	1.5mm amplitude at frequency of 5 to 60Hz (for 1 min) in each X, Y, Z direction for 10 min
Environment	Ambient temp.	0 to 50°C, storage: -10 to 60°C
	Ambient humi.	35 to 85%RH, storage: 35 to 85%RH
Approval	CE, RoHS	
Weight ^{*4}	Approx. 1.35kg (approx. 1.2kg)	

※1: Based on ambient temperature 25°C, ambient humidity 55%RH.
 ※2: RUN current varies depending on the input RUN frequency and max. RUN current at the moment varies also varies depending on the load.
 ※3: Max. input pulse frequency is max. frequency to be input and is not same as max. pull-out frequency or max. slewing frequency.
 ※4: The weight includes packaging. The weight in parenthesis is for unit only.
 ※Environment resistance is rated at no freezing or condensation.

■ Dimensions

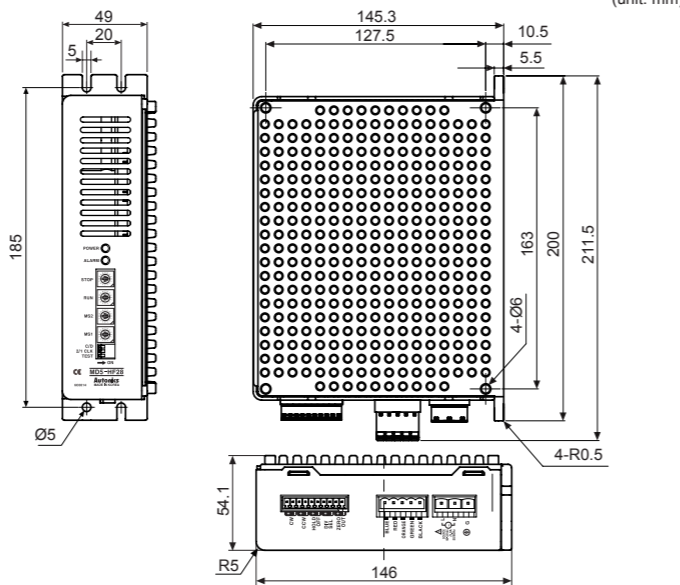

■ Time Chart

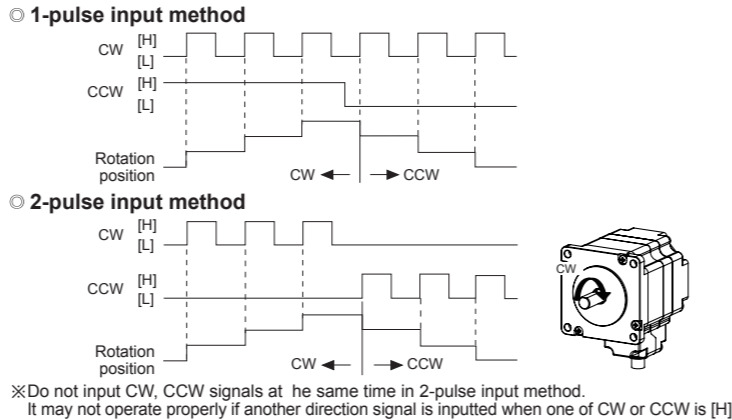

○ **HOLD OFF Function**
 ● This signal is for rotating motor's axis using external force or used for manual positioning.
 ● When hold off signal maintains over 1ms as [H], motor excitation is released.
 ● When hold off signal maintains over 1ms as [L], motor excitation is in a normal status.
 ※Must stop the motor for using this function.
 ※Refer to I/O Circuit and Connections.

■ I/O Circuit and Connections

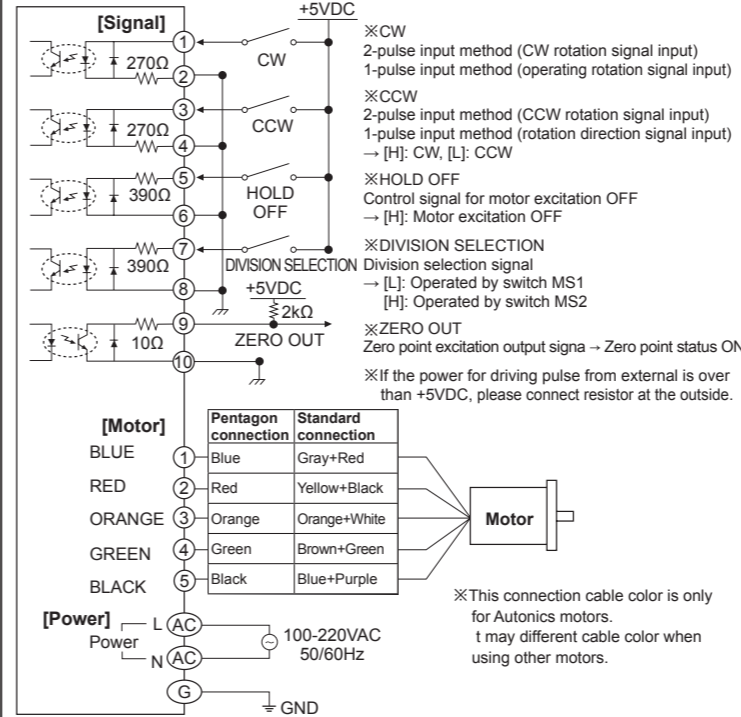

■ Functions

○ **Function selection DIP switch**

No	Name	Function	Switch position	
			ON	OFF (default)
1	TEST	Self diagnosis function	30rpm rotation	Not use
2	2/1 CLK	Pulse input method	1-pulse input method	2-pulse input method
3	C/D	Auto Current Down	Not use	Use

- **TEST**
 ● Self diagnosis function is for motor and driver test.
 ● This function makes the motor rotate with 30rpm in full step. Rotation speed varies with resolution set ing.
 ● Rotation speed = 30rpm/resolution
 ● In 1-pulse input method, it rotates to CCW, and in 2-pulse input method, it rotates to CW.
 ※Be sure that the TEST switch is OFF before supplying the power.
 If the TEST switch is ON, the motor operates immediately and it may be dangerous.
- **2/1 CLK**
 ● 1/2 CLK switch is to select pulse input method.
 ● 1-pulse input method: CW → operating rotation signal input, CCW → rotation direction signal input ([H]: CW, [L]: CCW)
 ● 2-pulse input method: CW → CW rotation signal input, CCW → CCW rotation signal input.
- **C/D (auto current down)**
 ● This function is to reduce the current provided for motor automatically for preventing severe motor's heat when motor stops.
 ● If motor RUN pulse is not applied, the current provided for motor reduces as the set STOP current.
 ※Be sure that when motor RUN current is reduced, the stop torque of motor also reduced.
 ※Set the STOP current by the STOP current setting switch.

○ **Setting RUN current**

Switch No	0	1	2	3	4	5	6	7	8	9	A	B	C	D	E	F
Current (A/Phase)	1.14	1.25	1.36	1.50	1.63	1.74	1.86	1.97	2.10	2.20	2.30	2.40	2.50	2.60	2.78	2.88

- RUN current setting is for the current provided for motor when the motor runs.
 ※When RUN current is increased, RUN torque of the motor is also increased.
 ※When RUN current is set too high, the heat is severe.
 ※Set RUN current within the range of motor's rated current according to its load.
 ※Change RUN current only when the motor stops.

○ **Setting STOP current**

Switch No	0	1	2	3	4	5	6	7	8	9	A	B	C	D	E	F
%	27	31	36	40	45	50	54	58	62	66	70	74	78	82	86	90

- STOP current setting is for the current provided for motor when the motor stops for preventing severe motor's heat.
 ● This setting is applied when using C/D (current down) function.
 ● Set ing value of STOP current is percentage (%) ratio of the set RUN current.
 E.g.) Set RUN current as 2.5A and STOP current as 40%.
 STOP current is set as 2.5A×0.4=1A.
 ※When STOP current is decreased, STOP torque of the motor is also decreased.
 ※When STOP current is set too low, the heat is lower.
 ※Change STOP current only when the motor stops.

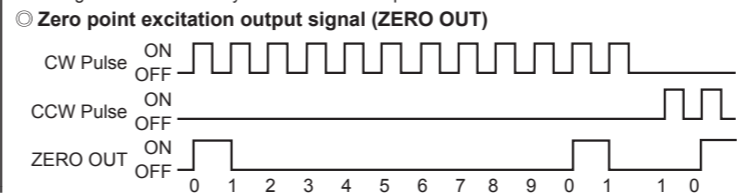

- This output indicates the initial step of excitation order of stepping motor and rotation position of motor axis.
- This signal outputs every 7.2° of rotation of the motor axis regardless of resolution. (50 outputs per 1 rotation of the motor.)
 E.g.) Full step: outputs one time by 10 pulses input.
 20-division: outputs one time by 200 pulses input.

○ Setting microstep (Microstep: Resolution)

Switch No	0	1	2	3	4	5	6	7	8	9	A	B	C	D	E	F
Resolution	1	2	4	5	8	10	16	20	25	40	50	80	100	125	200	250
Step angle	0.72°	0.36°	0.18°	0.144°	0.09°	0.072°	0.045°	0.036°	0.0288°	0.018°	0.0144°	0.009°	0.0072°	0.00576°	0.0036°	0.00288°

- **Setting resolution (same as MS1, MS2)**
 ● The MS1, MS2 switches is for resolution setting.
 ● Select MS2 or MS2 by DIVISION SELECTION signal ([L]: MS1, [H]: MS2)
 ● Select the step angle (motor rotation angle per 1 pulse).
 ● The set step angle is dividing basic step angle (0.72°) of 5-phase stepping motor by setting value.
 ● The calculation formula of divided step angle is as below.

$$\text{Set step angle} = \frac{\text{Basic step angle (0.72°)}}{\text{Resolution}}$$

- When using geared type motor, the angle is step angle divided by gear ratio.
 Step angle / gear ratio = Step angle applied gear
 E.g.) 0.72° / 10 (1:10) = 0.072°
 ※Must stop the motor before changing the resolution.

○ Alarm function

- **Overheat**
 : When the temperature of driver base is over 80°C, alarm LED (Red) turns ON and motor stops with holding the excision.
 Turn OFF the power and remove the causes. Turn ON the power and alarm output is OFF.
- **Overcurrent**
 : When overcurrent is applied from motor damage by burn, driver damage, or error, alarm LED (Red) is flashed. When overcurrent occurs, the motor becomes HOLD OFF.
 Turn OFF the power and remove the causes to normal operation.

■ Caution during Use

- Follow instructions in 'Cautions during Use'.
Otherwise, it may cause unexpected accidents.
- Re-supply power after min. 1 sec from disconnected power.
- Do not input CW, CCW signal at the same time in 2-pulse input method.
- When the signal input voltage is exceeded the rated voltage, connect additional resistance at the outside.
- Set RUN current within the range of motor's rated current depending on the load.
When the rated motor current is over, the heat may be increased and motor may be damaged.
- If motor stops, switching for STOP current executed by the current down function.
When hold off signal is [H] or current down function is off, the switching does not execute.
- Use twisted pair (over 0.2mm²) for the signal cable which should be shorter than 2m.
- The thickness of cable should be same or thicker than the motor cable's when extending the motor cable.
- Keep the distance between power cable and signal cable more than 10cm.
- For heat radiation of the driver, install a fan as below figure.
(distance between the fan and the unit: approx. within 70mm,
 ◎ min. airflow: 0.71m³/min at least)

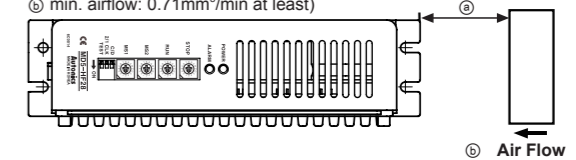

- If the TEST switch is ON, the motor operates immediately and it may be dangerous.
- Do not change any setting switches (function, run/stop current, resolution switches) during the operation or after supplying power.
Failure to follow this instruction may result in malfunction.
- Motor vibration and noise can occur in specific frequency period
 ◎Change motor installation method or attach the damper.
 ◎Use the unit out of the dedicated frequency range when vibration and noise occurs due to changing motor RUN speed.
- For using motor, it is recommended to maintenance and inspection regularly.
 ◎Unwinding bolts and connection parts for the unit installation and load connection
 ◎Strange sound from ball bearing of the unit
 ◎Damage and stress of lead cable of the unit
 ◎Connection error with motor
 ◎Inconsistency between the axis of motor output and the center, concentric (eccentric, declination) of the load, etc.
- This product does not prepare protection function for a motor.
- This unit may be used in the following environments.
 ◎Indoors (in the environment condition rated in 'Specifications')
 ◎Altitude max. 2,000m
 ◎Pollution degree 2
 ◎Installation category II

■ Major Products

- Photoelectric Sensors
- Fiber Optic Sensors
- Door Sensors
- Door Side Sensors
- Area Sensors
- Proximity Sensors
- Pressure Sensors
- Rotary Encoders
- Connector/Sockets
- Switching Mode Power Supplies
- Control Switches/Lamps/Buzzers
- I/O Terminal Blocks & Cables
- Stepper Motors/Drivers/Motion Controllers
- Graphic/Logic Panels
- Field Network Devices
- Laser Marking System (Fiber, CO₂, Nd: YAG)
- Laser Welding/Cutting System
- Temperature Controllers
- Temperature/Humidity Transducers
- SSRs/Power Controllers
- Counters
- Timers
- Panel Meters
- Tachometer/Pulse (Rate) Meters
- Display Units
- Sensor Controllers